

DAQSTATION DX100P/DX200P

Please make the following alterations to the Operation Guide IM04L05A01-02E (see underlined text).

Page 8 “Installation Procedure (Panel Mount Type)”

2. As shown in the figure below, mount the DXP to the panel using the mounting brackets that came with the package.

- Use two brackets to support the top and bottom or the left and right sides of the case. (Remove the seal that is covering the holes for the mounting brackets beforehand.)
- The proper torque for tightening the mounting screws is 0.7 to 0.9 N·m.
- Mount the DXP to the panel according to the procedure below.
 - First, attach the two mounting brackets and temporarily fasten the attachment screws.
 - Next, fix the DXP in place by tightening the attachment screws with the appropriate torque. When the DXP is approximately perpendicular to the panel as you fasten the screws, press the mounting bracket against the case so that they are in contact with each other.

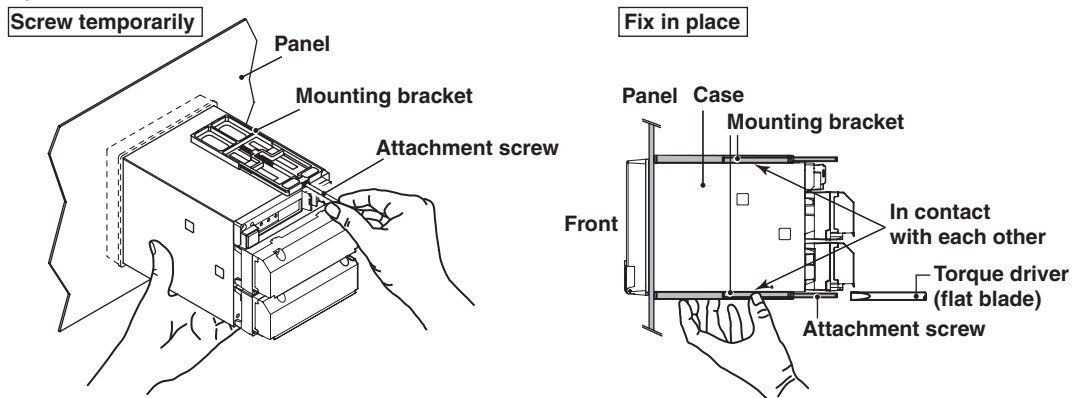

Page 12 “Wiring Procedure (for Panel Mount Type)”

3. Connect the power supply wires and the protective ground wire to the power terminals. The proper torque for tightening the screw is 1.4 to 1.5 N·m (12.4 to 13.2 inch·lbs).